



ООО «Торговый Дом «Прометей»

142410, г. Ногинск, Московская область, ул. Бетонная, д.3

Контакты: (495) 979-76-05

(977) 316-7605

(903)100-34-47

ICQ: 408280786

E-mail: info@tdprometey.ru

Сайт: www.tdprometey.ru

www.zapornaya-armatura.tdprometey.ru

Каталог

Люки нержавеющей стали разные

Люки из нержавеющей стали характеризуются высоким качеством, стойкостью к различным средам и подтверждены соответствующими сертификатами.

Все детали люков и заслонок, предлагаемых нашей компанией, такие как винты, скобы и рукоятки изготовлены из марки стали **AISI 304, AISI 316L**.

Стандартные уплотнения обычно изготовлены из резины, способной контактировать с пищевыми продуктами в температурном диапазоне от -35 до +180°C.

Наша компания по запросу клиента также предлагает уплотнители для люков и крышек из таких материалов как: Silicon, Viton, NBR, EPDM.

Выбор уплотнительного материала очень важен для соблюдения температурного режима и композиционных характеристик продукции. Полирование поверхности ведется до зеркального блеска со средней шероховатостью поверхности $\pm 1,4-0,6$, также возможно анодное покрытие. При изготовлении люков и заслонок на заводе-изготовителе произведены испытания на воздействие давлением, растяжением и разрывом, результаты этих испытаний приводятся в каталоге.

Рекомендовано при эксплуатации придерживаться правил и периодически заменять элементы, находящиеся в постоянном контакте с жидкостями. Это заметно увеличит срок эксплуатации крышек и люков.

Люки круглые без давления AISI 304/316

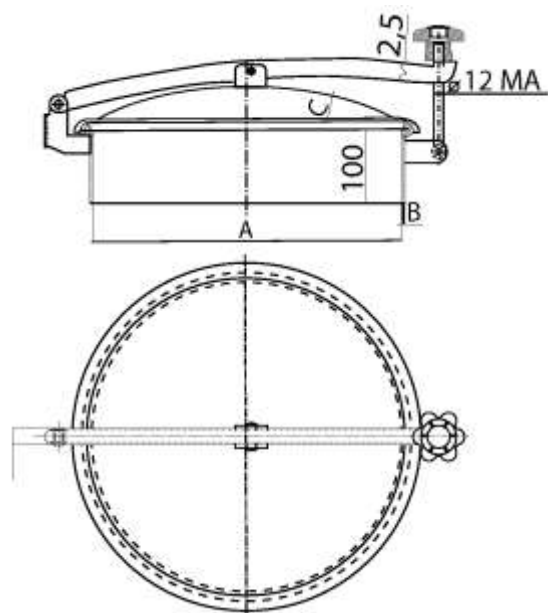

DN	Высота обечайки (мм)	Толщина обечайки (мм)	Толщина крышки (мм)	Рабочее давление (bar)	Уплотнение	Вес кг
200	100	2	2	0,1	SILICON/EPDM	4
300	100	2	2	0,1	SILICON/EPDM	5
400	100	2	2	0,1	SILICON/EPDM	8
450	100	2	2	0,1	SILICON/EPDM	9
500	100	2	2	0,1	SILICON/EPDM	10
600	100	2	2	0,1	SILICON/EPDM	12

Non-Pressure Round Manway

Model No.: TMN01

APPLICATION

The round stainless steel manway with non-pressure is used on top of tanks or containers, especially in the dairy industry, where a hygienic closeable mean of access to the interior of the tank is required.



DESIGN AND FEATURES

- Outward opening manway door type
- Handle wheel in material of Nylon or Stainless steel.
- Self-sealing double lip seal to prevent fluids spraying out.

TECHNICAL DATA

Working pressure: No pressure
Min. Temperature: - 20°C
Max. Temperature: + 100°C (Silicon)

MATERIAL

Cover Body: SS304 or SS316L
Handle Wheel: Nylon or SS304
Gasket: Silicon, EPDM, FPM
Inside Surface Finish: Mirror
Outside Surface Finish: Satin or Mirror

PARTS LIST

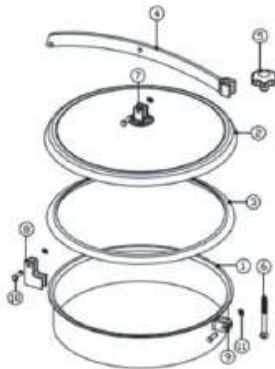

Item	Description	Material	Qty
1	Frame	1.4301/1.4404	1
2	Cover	1.4301/1.4404	1
3	Gasket	Silicone *	1
4	Bracket	T304	1
5	Handle	Nylon/T304	1
6	Swing bolt	T304	1
7	Up hinge Support	T304	1
8	Back hinge Support	T304	1
9	Front hinge Support	T304	1
10	Pin	T304	3
11	Lock ring	T304	3

* Gasket Material Option: Silicon, EPDM, FPM.

DIMENSIONS(MM)

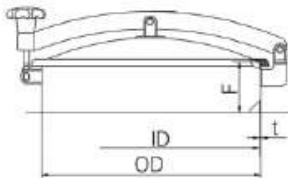

Code	OD	ID	t	F
TMN01200	200	194	3	100
TMN01250	250	244	3	100
TMN01300	300	294	3	100
TMN01350	350	344	3	100
TMN01400	400	394	3	100
TMN01430	430	424	3	100
TMN01450	450	444	3	100
TMN01500	500	494	3	100
TMN01600	600	594	3	100



	A	B	C	D	E	N	P,max
500 mm	2,0	2,0	95,0	150,0	540,0	6,0	0,3

Люки круглые под давление -1/+3 бара AISI 304/316

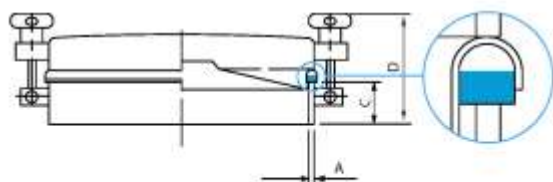
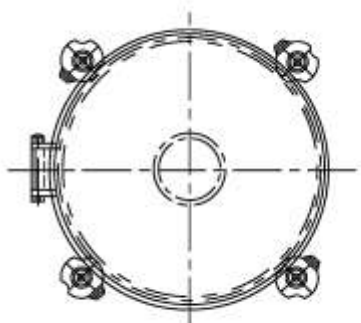

DN	Высота обечайки (мм)	Толщина обечайки (мм)	Толщина крышки (мм)	Рабочее давление (бар)	Уплотнение	Количество ручек (шт)	Вес кг
300	100	3	3	3	SILICON/EPDM	4	12
400	100	3	3	3	SILICON/EPDM	6	16
500	100	3	3	3	SILICON/EPDM	6	22
600	100	3	3	2,5	SILICON/EPDM	6	25

Люки круглые под давление -1/+5 бар AISI 304/316

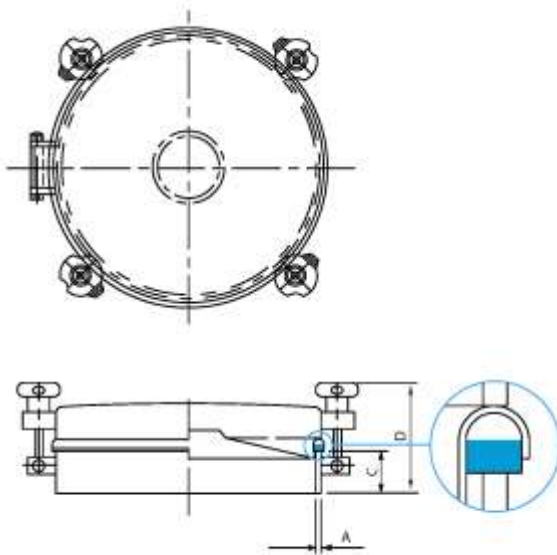

DN	Высота обечайки (мм)	Толщина обечайки (мм)	Толщина крышки (мм)	Рабочее давление (bar)	Уплотнение	Количество ручек (шт)	Вес кг
300	100	3	3	-1/+5	SILICON/EPDM	5	12
400	100	3	3	-1/+5	SILICON/EPDM	8	16
500	100	3	3	-1/+5	SILICON/EPDM	10	22

Pressure Round Manway

Model No.: TMP01

APPLICATION

Pressure round stainless steel manway is used on top of pressurized tanks and containers where closeable means of access to the interior of the vessel is required.

DESIGN AND FEATURES

- Outward opening manway door type
- Option with sight glass.
- Handle wheel in material of Nylon or Stainless steel.
- Frame Height and thickness available on request



TECHNICAL DATA

Working pressure: 2-4Bar
 Max. Temperature: + 100°C (Silicon)

MATERIAL

Cover Body: SS304 or SS316L
 Handle Wheel: Nylon or SS304
 Gasket: Silicon, EPDM, FPM
 Inside Surface Finish: Mirror
 Outside Surface Finish: Satin or Mirror

PARTS LIST

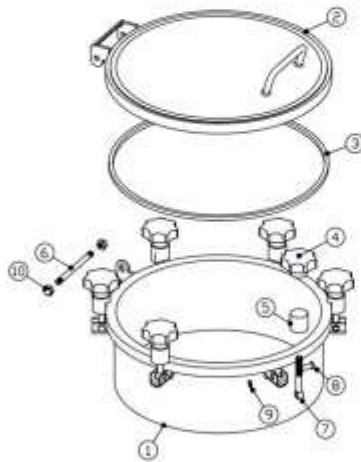

Item	Description	Material	Qty
1	Frame	1.4301/1.4404	1
2	Cover	1.4301/1.4404	1
3	Gasket	Silicone *	1
4	Handle	Nylon/1.4301	4*
5	Hub	T304	4*
6	Screw	T304	1
7	Swing Bolt	T304	4*
8	Pin	T304	4*
9	Lock Ring	T304	4*
10	Nut	T304	2

* Gasket Material Option: Silicon, EPDM, FPM.

* Handles qty depends on size, pressure and temperature.

DIMENSIONS(MM)

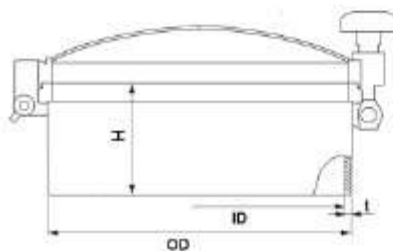

Code	OD	ID	t	H
TMP01200	200	194	3	100
TMP01250	250	244	3	100
TMP01300	300	294	3	100
TMP01350	350	344	3	100
TMP01400	400	394	3	100
TMP01430	430	424	3	100
TMP01450	450	444	3	100
TMP01500	500	494	3	100
TMP01600	600	594	3	100

Pressure Round Manway with Sight Glass

Model No.: TMP02

APPLICATION

Pressure round manway with sight glass is used on top of pressurized tanks and containers where closeable means of access to the interior of the vessel is required.

DESIGN AND FEATURES

- With Flange Sight Glass on the top
- Outward opening manway door type
- Handle wheel in material of Nylon or Stainless steel.
- Frame Height and thickness available on request



TECHNICAL DATA

Working pressure: 1-4Bar
Max. Temperature: + 100°C (Silicon)

MATERIAL

Cover Body: SS304 or SS316L
Handle Wheel: Nylon or SS304
Gasket: Silicon, EPDM, FPM
Inside Surface Finish: Mirror
Outside Surface Finish: Satin or Mirror

DIMENSIONS(MM)

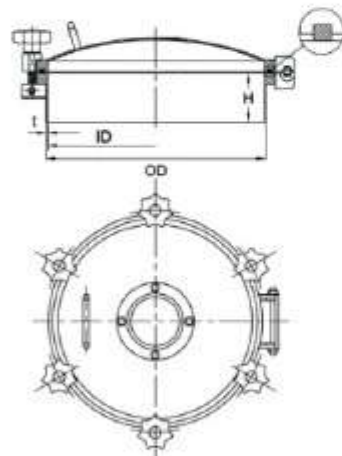

Code	OD	ID	t	H	Sight Glass
TMP02200	200	104	3	100	DN80
TMP02250	250	244	3	100	DN80
TMP02300	300	204	3	100	DN80
TMP02350	350	344	3	100	DN80
TMP02400	400	304	3	100	DN80
TMP02430	430	424	3	100	DN80
TMP02450	450	444	3	100	DN80
TMP02500	500	404	3	100	DN100
TMP02600	600	504	3	100	DN100

* Gasket Material Option: Silicon, EPDM, FPM.

* Handles qty depends on size, pressure and temperature.

Люки круглые под давление со стеклянной крышкой AISI 304/316

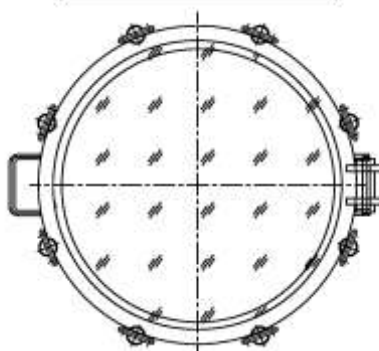
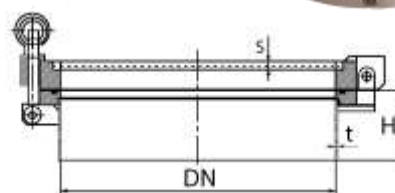

DN	Высота обечайки (мм)	Толщина обечайки (мм)	Толщина крышки (мм)	Количество ручек (шт)	Рабочее давление (bar)	Уплотнение	Вес кг
300	100	3	3	4	3	EPDM/SILICON	20
400	100	3	3	4	3	EPDM/SILICON	22
500	100	3	3	6	3	EPDM/SILICON	25

View Glass Manway

Model No.: TMP03

APPLICATION

View Glass Manway is used on top of pressurized tanks and containers where closeable means of access to the interior of the vessel is required.

DESIGN AND FEATURES

- Full Glass cover for easily viewing
- Outward opening manway door type
- Handle wheel in material of Nylon or Stainless steel.
- Frame Height and thickness available on request



TECHNICAL DATA

Working pressure: 1Bar
Max. Temperature: + 100°C (Silicon)

MATERIAL

Cover Body: SS304 or SS316L
Handle Wheel: Nylon or SS304
Gasket: Silicon, EPDM, FPM
Inside Surface Finish: Mirror
Outside Surface Finish: Satin or Mirror

PARTS LIST

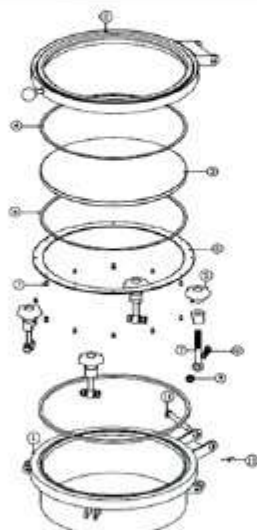

Item	Description	Material	Qty
1	Frame	1.4301/1.4404	1
2	Cover	1.4301/1.4404	1
3	Glass	Tempered Glass	1
4	Gasket	Silicone *	2
5	Handle	Nylon/1.4301	4*
6	Flange	T304	1
7	Swing Bolt	T304	4*
8	Screw	T304	4*
9	Nut	T304	4*
10	Cotter Pin	T304	1
11	Pin	T304	1

* Gasket Material Option: Silicon, EPDM, FPM.

* Handles qty depends on size, pressure and temperature.

DIMENSIONS(MM)

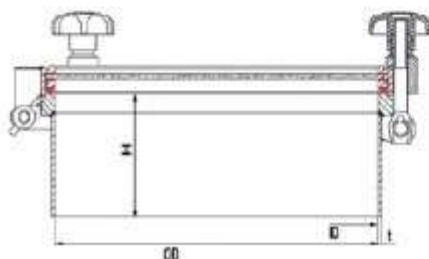

Code	OD	ID	t	H
TMP03300	300	294	3	100
TMP03350	350	344	3	100
TMP03400	400	394	3	100
TMP03430	430	424	3	100
TMP03450	450	444	3	100
TMP03500	500	494	3	100
TMP03600	600	594	3	100

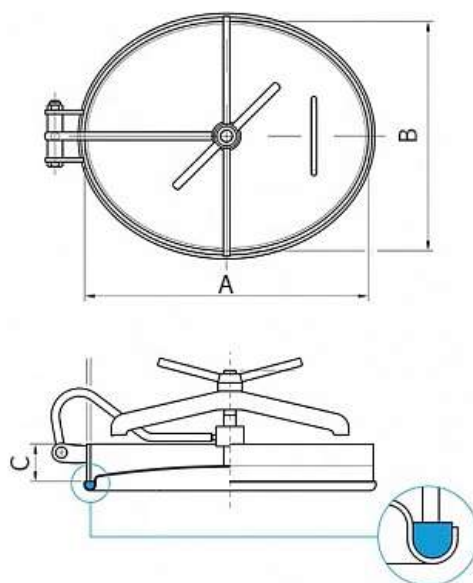

Размер А (мм)	Размер В (мм)	Высота обечайки (мм)	Толщина обечайки (мм)	Толщина крышки (мм)	Рабочее давление (bar)	Уплотнение	Вес кг
435	335	80	8	3	6	EPDM/SILICON	12
535	435	80	10	3	6	EPDM/SILICON	21



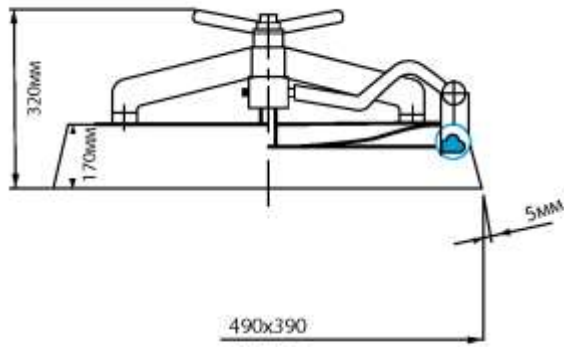

Размер (мм)	Размер (мм)	Высота обечайки (мм)	Толщина обечайки (мм)	Толщина крышки (мм)	Рабочее давление (bar)	Уплотнение	Вес кг
490 внеш	390 внеш	170	5	4	3	EPDM/SILICON	12
380 внутр	280 внутр						
580 внеш	480 внеш	135	5	4	3	EPDM/SILICON	21
440 внутр	340 внутр						

Elliptical Manway

Model No.: TME01

APPLICATION

The elliptical Manways are used on tanks and containers used in a wide range of sanitary applications such as wine, beverages, dairy and foodstuffs. They are designed to fit where a closeable mean of access to the interior of the vessel, situated below the liquid level, is required.

DESIGN AND FEATURES

- Inward opening manway door type
- Gasket Material Option: Silicon, EPDM, FPM
- Frame Height and thickness available on request



TECHNICAL DATA

Working pressure: 0.5-3Bar
Max. Temperature: + 100°C (Silicon)

MATERIAL

Cover Body: SS304 or SS316L
Gasket: Silicon, EPDM, FPM
Inside Surface Finish: Mirror
Outside Surface Finish: Satin or Mirror

PARTS LIST

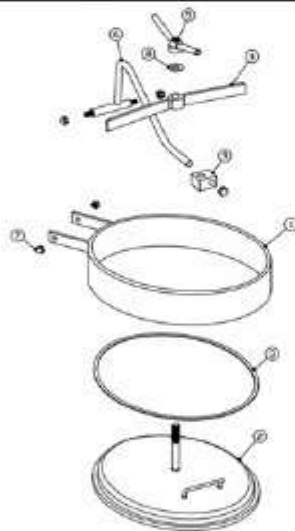

Item	Description	Material	Qty
1	Frame	1.4301/1.4404	1
2	Cover	1.4301/1.4404	1
3	Gasket	Silicone *	1
4	Bracket	T304	1
5	Spanner Handle	T304	1
6	Suspension arm	T304	1
7	Nut	T304	5
8	Trust collar	T304	1
9	Hub	T304	1

* Gasket Material Option: Silicon, EPDM, FPM.

DIMENSIONS(MM)

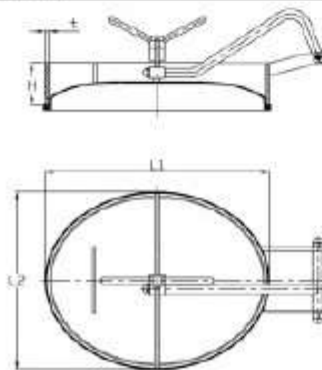

Code	L1	L2	t	H
TME01430	430	330	8	75
TME01530	530	430	8	80

Elliptical Manway

Model No.: TME02

APPLICATION

The elliptical Manways are used on tanks and containers used in a wide range of sanitary applications such as wine, beverages, dairy and foodstuffs. They are designed to fit where a closeable mean of access to the interior of the vessel, situated below the liquid level, is required.

DESIGN AND FEATURES

- Inward opening manway door type
- Gasket Material Option: Silicon, EPDM, FPM
- Frame Height and thickness available on request



TECHNICAL DATA

Working pressure: 1-3Bar
Max. Temperature: + 100°C (Silicon)

MATERIAL

Cover Body: SS304 or SS316L
Gasket: Silicon, EPDM, FPM
Inside Surface Finish: Mirror
Outside Surface Finish: Satin or Mirror

PARTS LIST

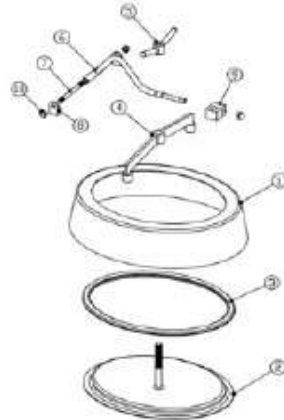

Item	Description	Material	Qty
1	Frame	1.4301/1.4404	1
2	Cover	1.4301/1.4404	1
3	Gasket	Silicone *	1
4	Bracket	T304	1
5	Top Nut	T304	1
6	Suspension arm	T304	1
7	Screw	T304	2
8	Hinge ear	T304	2
9	Hub	T304	1
10	Nut	T304	3

* Gasket Material Option: Silicon, EPDM, FPM.

DIMENSIONS(MM)

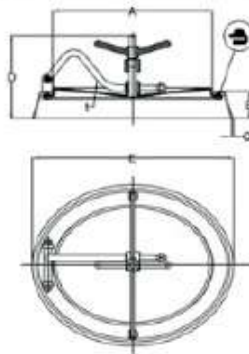

Code	A	E	C	B	t
TME02555	440	340	555	455	75
TME02565	440	340	565	465	100
TME02580	440	340	580	480	133

Люки прямоугольные под давление AISI 304/316

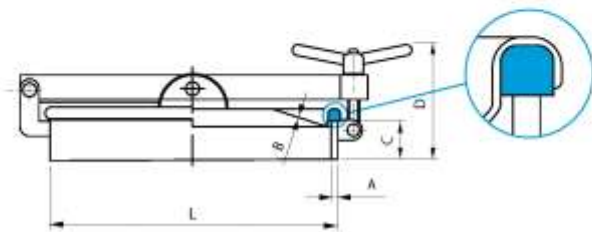
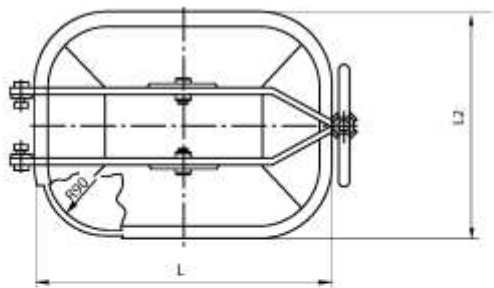

Размер	Размер	Высота обечайки (мм)	Толщина обечайки (мм)	Толщина крышки (мм)	Рабочее давление P bar	Уплотнение	Вес кг
435	325	70	8	3	0,15	EPDM/SILICON	13
535	435	90	9	3	0,12	EPDM/SILICON	18

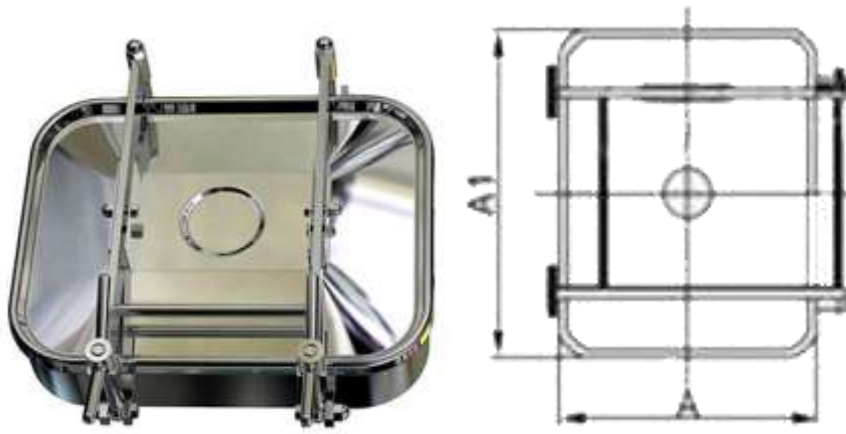

Размер A (мм)	Размер A1 (мм)	Высота обечайки (мм)	Толщина обечайки (мм)	Толщина крышки (мм)	Рабочее давление P bar	Уплотнение	Вес кг
535	435	100	10	3	0,12	EPDM/SILICON	18

Rectangular Manway

Model No.: TMR01

APPLICATION

The Rectangular manhole covers are used in bottling and washing machines and industries where removal of pulp from the bottom of a tank must be done occasionally.

DESIGN AND FEATURES

- Outward opening manway door type
- Handle wheel in material of Nylon or Stainless steel.
- Gasket Material Option: Silicon, EPDM, FPM
- Frame Height and thickness available on request



TECHNICAL DATA

Working pressure: 0.5Bar
Max. Temperature: + 100°C (Silicon)

MATERIAL

Cover Body: SS304 or SS316L
Handle Wheel: Nylon or SS304
Gasket: Silicon, EPDM, FPM
Inside Surface Finish: Mirror
Outside Surface Finish: Satin or Mirror

PARTS LIST

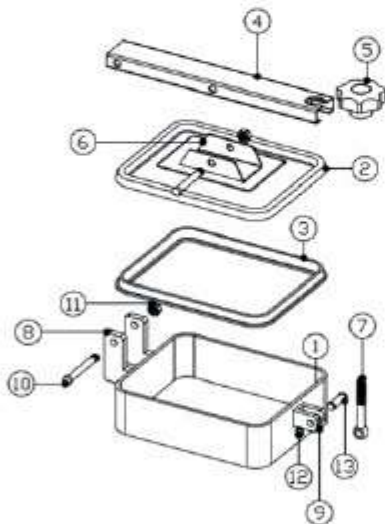

Item	Description	Material	Qty
1	Frame	1.4301/1.4404	1
2	Cover	1.4301/1.4404	1
3	Gasket	Silicone *	1
4	Bracket	T304	1
5	Handle	Plastic/T304	1
6	Up hinge support	T304	1
7	Swing bolt	T304	1
8	Back hinge support	T304	1
9	Front hinge support	T304	1
10	Screw	T304	1
11	Nut	T304	1
12	Lock ring	T304	1
13	Pin	T304	1

* Gasket Material Option: Silicon, EPDM, FPM.

DIMENSIONS(MM)

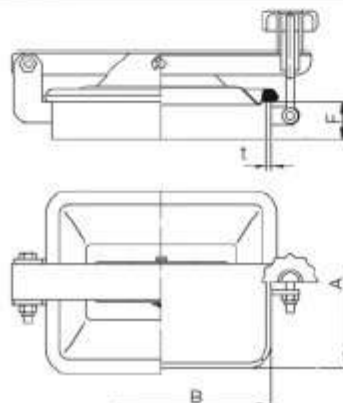

Code	A	B	t	F
TMR01250	150	250	5	75

Rectangular Manway

Model No.: TMR02

APPLICATION

The Rectangular manhole covers are used in bottling and washing machines and industries where removal of pulp from the bottom of a tank must be done occasionally.

DESIGN AND FEATURES

- Outward opening manway door type
- Gasket Material Option: Silicon, EPDM, FPM
- Frame Height and thickness available on request



TECHNICAL DATA

Working pressure: 0.5Bar
 Max. Temperature: + 100°C (Silicon)

MATERIAL

Cover Body: SS304 or SS316L
 Gasket: Silicon, EPDM, FPM
 Inside Surface Finish: Mirror
 Outside Surface Finish: Satin or Mirror

PARTS LIST

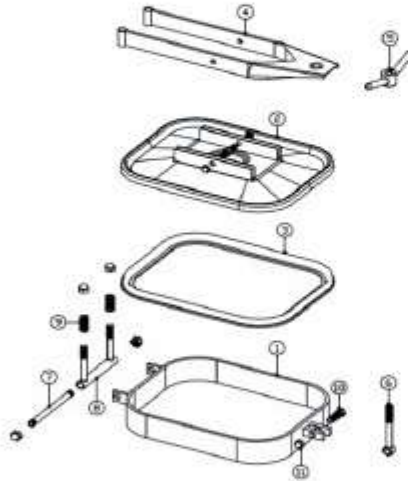

Item	Description	Material	Qty
1	Frame	1.4301/1.4404	1
2	Cover	1.4301/1.4404	1
3	Gasket	Silicone	1
4	Arm	T304	1
5	Top Nut	T304	1
6	Swing bolt	T304	1
7	Screw	T304	1
8	Back hinge support	T304	1
9	Spring	T304	2
10	Screw	T304	3
11	Nut	T304	7

* Gasket Material Option: Silicon, EPDM, FPM.

DIMENSIONS(MM)

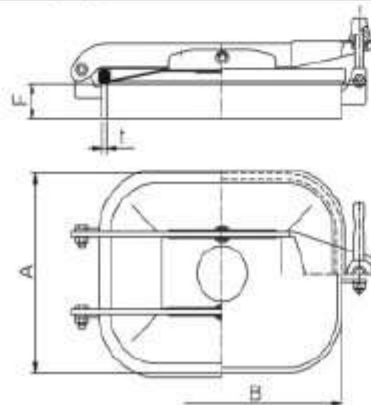

Code	A	B	t	F
TMR02430	330	430	8	80

Rectangular Manway

Model No.: TMR03

APPLICATION

The Rectangular manhole covers are used in bottling and washing machines and industries where removal of pulp from the bottom of a tank must be done occasionally.

DESIGN AND FEATURES

- Outward opening manway door type
- Gasket Material Option: Silicon, EPDM, FPM
- Frame Height and thickness available on request



TECHNICAL DATA

Working pressure: 0.5Bar
Max. Temperature: + 100°C (Silicon)

MATERIAL

Cover Body: SS304 or SS316L
Gasket: Silicon, EPDM, FPM
Inside Surface Finish: Mirror
Outside Surface Finish: Satin or Mirror

PARTS LIST

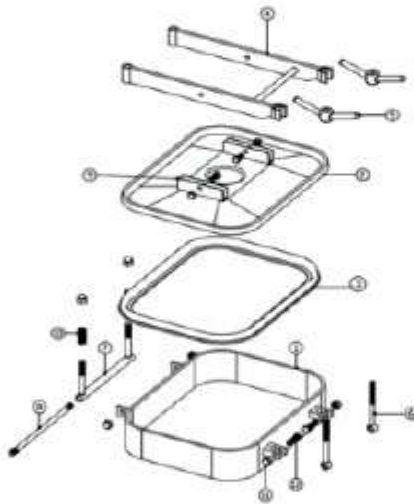

Item	Description	Material	Qty
1	Frame	1.4301/1.4404	1
2	Cover	1.4301/1.4404	1
3	Gasket	Silicone	1
4	Bracket	T304	1
5	Top Nut	T304	2
6	Swing bolt	T304	2
7	Screw	T304	1
8	Screw	T304	1
9	Up hinge support	T304	2
10	Spring	T304	2
11	Nut	T304	8
12	Screw	T304	4

* Gasket Material Option: Silicon, EPDM, FPM.

DIMENSIONS(MM)

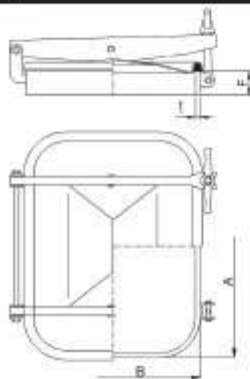

Code	A	B	t	F
TMR03430	430	330	8	80

Уплотнения для люков



Сфера применения и характеристики прокладок и уплотнений из эластомера.

Торговое наименование	Техническое наименование	Сфера применения	Температура ограничения	Не рекомендуется для
NBR	сополимер бутадиена с высоким содержанием акрилонитрила	углеводы с содержанием ароматических соединений менее 45%, природный газ, воздух, воды, морская вода, спирты, двухатомные спирты.	-20°C /+100°C -4°F /+212°F	растворители, бензол, диметилбензол
ЭТИЛЕН ПРОПИЛЕН высокотемпературный (EPDM HT)	терполимер этилена и пропилена	вода, пар, морская вода, солевые растворы, абразивные материалы, фосфаты, эфиры, кетоны, пищевые щелочные соединения, жидкости и твердые вещества	-35°C /+150°C -31°F /+302°F	растворители, бензол, диметилбензол
СИЛИКОН Q	кремнийсодержащий метилвенил	напитки, пищевые продукты	-30°C /+100°C -22°F /+302°F	углеводы, растворители, пары
VITON* FPM	сополимер гексафторпропилен а фтористого винилидена	углеводороды с высоким содержанием ароматических соединений, минеральные и галогенозамещенные кислоты,	-10°C /+160°C -14°F /+320°F	пары, кетоны, амины, эфиры, щелочи

		фосфорная кислота, ароматические и алифатические эфиры		
NEOPRENE* CR	полихлоропрен	масла, разбавленные минеральные кислоты, щелочи, жиры	-18°C /+90°C 0°F /+194°F	кетоны, концентрированны ые кислоты, растворители для красок
НАТУРАЛЬНЫЙ КАУЧУК (NR)	латекс (растительный)	абразивные материалы	-35°C /+65°C -31°F /+149°F	пары, углеводороды, масла
TEFLON* (P.T.F.E)	поли	корродирующие вещества, растворители	-40°C /+180°C -40°F /+356°F	абразивные материалы, газообразный фтор, щелочные металлы в расплавленном состоянии

* - торговая марка DU PONT

Вышеприведенная таблица является ориентировочной. Многие факторы влияют на размеры коррозии (тип раствора - концентрация - температура - наличие примесей и т.п.). Окончательная оценка производится клиентом в соответствии с областью применения оборудования и его характеристиками.